

COOLEEDGE

COOLEEDGE TILE EXTERIOR - SPECIFICATIONS

PROJECT		REFERENCE TYPE	
SPECIFIED BY		QUANTITY	
DATE		NOTE	For Luminous Surfaces

SYSTEM OVERVIEW

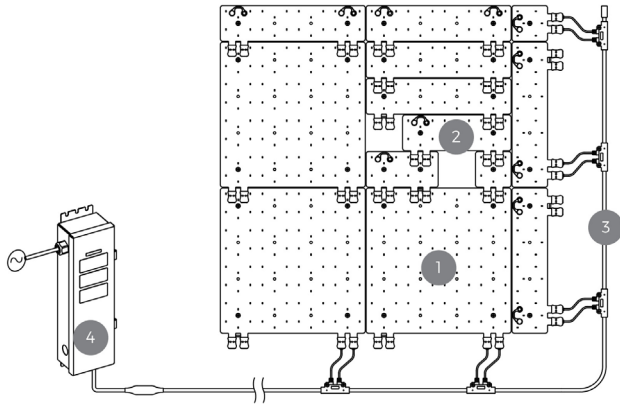

Illuminate facades, canopies, entrances (including arches & columns) and large-scale graphics.

1	TILE Exterior
2	TILE Exterior Fit - 1, 2, 3, or 4 (<i>optional</i>)
3	TILE Exterior Starter Cable
4	LED Driver

Also available: *TILE Exterior Fit Kit*

GENERAL

Location	Wet location (not for submersion)
Operating Temp.	-20 - +55°C
Ingress Protection	min. IP65 (on all system components)
Storage Temp.	-40 - +70°C
Electrical Connections	Proprietary tool-less IP65 snap connectors
Base Material	Thermally Stabilized Flexible PET
Exposure	Not for use in direct sunlight - intended for installation behind luminous surface materials

SPECIFICATION

CE IP65 compliant wet location lighting system inclusive of flexible light emitting sheets, connectors and low voltage cables. All system components listed above must have a minimum ingress protection rating of IP65. Light output from the system must be +/- 10% of 6450/3225 lm/sqm. Color Rendering index (CRI) must be >80 and color consistency between light sheets must be typical 2 SDCM. Electrical connections between light emitting sheets and between cables and light emitting sheets must be tool-less and allow more than one connect/disconnect iteration. System must be configurable on-site to accommodate obstacles, angles, and curves; and must not require the use of additional sealants or tapes of any type. System warranty must be a minimum of 5 years.

FEATURES

- The TILE Exterior system including light sheets, connectors, and cables is rated for wet location environments
- “True-Temp” optics ensure minimal CCT shift from the rated color temperature of the LEDs
- Proprietary waterproof snap connectors maintain the simplicity of tool-less connections unique to Cooleedge TILE products
- Field configurable to manage obstacles such as standoffs and conform to shapes and unusual dimensions where necessary
- Constant lumen output and high color consistency ensure seamless illumination through exterior surface materials

Cooleedge Lighting reserves the right to change materials or modify the design of its product without notification as part of the company's continuing product improvement program.

COOLEGE TILE EXTERIOR - SPECIFICATIONS

PHOTOMETRICS¹

Light Output (lm) - per TILE	600, 300
Light Output (lm/sqm)	6450, 3225
Correlated Color Temperature (CCT)	2700K, 3000K, 3500K, 4000K, 5700K
Color Rendering Index (CRI)	≥ 80
Color Uniformity	2 SDCM (typical)
Lumen Maintenance ²	L80 = 50,000hr

¹ Photometric files available from cooledgelighting.com

² Based on LM80 data & TM-21 calculations

Each Cooledge TILE Exterior light emitting sheet is scanned using a proprietary process that measures the flux, color uniformity, and Color Rendering index (CRI) to ensure that it meets stringent specifications for optical performance .

POWER

Light Output (lm)	CCT	Power (W)	Power (W/sqm)
600	2700K	5.4	58
	3000K	5.1	55
	3500K	5.0	54
	4000K	5.0	54
	5700K	5.0	54
300	2700K	2.7	29
	3000K	2.6	28
	3500K	2.5	27
	4000K	2.5	27
	5700K	2.5	27

CERTIFICATIONS



UL 2108 Wet Location



RoHS

WARRANTY



5 Year Limited Warranty:
Parts and workmanship when
used with a Cooledge approved
power supply.

1 TILE EXTERIOR

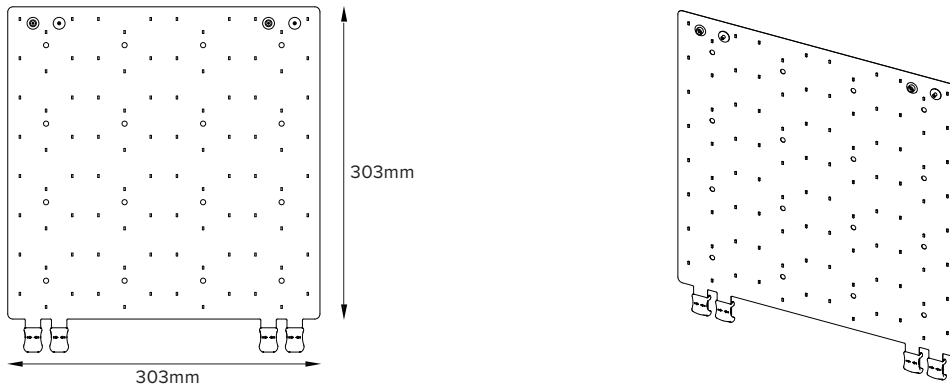

HOW TO ORDER

TILE	-	EXT	-	-	-
<u>PRODUCT</u> TILE		<u>TYPE</u> EXT = Exterior		<u>FLUX</u> 600 = 600lm 300 = 300lm	<u>CCT</u> 27 = 2700K 30 = 3000K 35 = 3500K 40 = 4000K 57 = 5700K

Example: TILE-EXT-600-40

2 TILE EXTERIOR FIT

Purpose: Individually sealed smaller TILE Exterior segments used to negotiate obstacles such as standoffs and supports, accommodate angles and curves, or fill spaces at the edges of layouts.

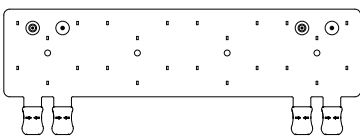

TACC-EXT-FIT-xxx-yy-4

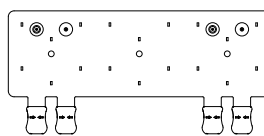

TACC-EXT-FIT-xxx-yy-3

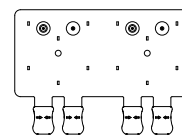

TACC-EXT-FIT-xxx-yy-2

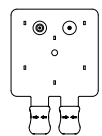

TACC-EXT-FIT-xxx-yy-1

HOW TO ORDER

TACC	-	EXT	-	FIT	-	-	-	
<u>PRODUCT</u> TACC = TILE Accessory		<u>TYPE</u> EXT = Exterior		<u>KIT</u> FIT = Fit Segment		<u>FLUX</u> 600 = 600lm 300 = 300lm	<u>CCT</u> 27 = 2700K 30 = 3000K 35 = 3500K 40 = 4000K 57 = 5700K	<u>SEGMENTS</u> 1 2 3 4

Example: TACC-EXT-FIT-300-35-4

ADDITIONAL ACCESSORIES: TILE EXTERIOR FIT KIT

Purpose: A set of TILE Exterior Fit segments and connectors available to address unexpected obstacles encountered on-site. The kit is designed to fill any void space around objects within a 305mm x 305mm area. TILE Exterior Fit Kits are pre-packaged for rapid shipment to mitigate delays.

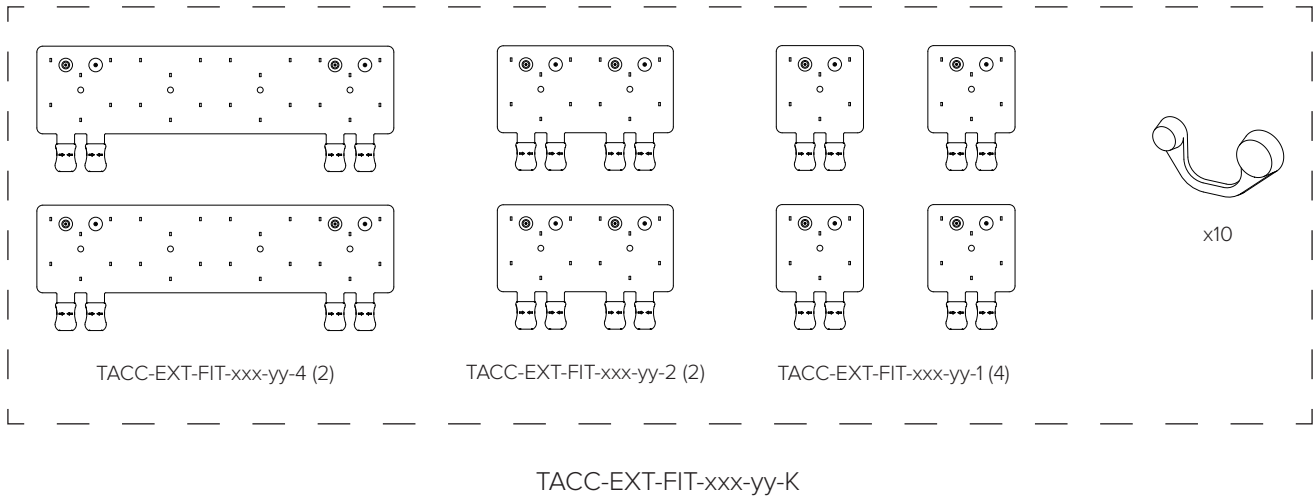

HOW TO ORDER

TACC	-	EXT	-	FIT	-	-	-	K
<u>PRODUCT</u> TACC = TILE Accessory		<u>TYPE</u> EXT = Exterior		<u>KIT</u> FIT = Fit Segment		<u>FLUX</u> 600 = 600lm 300 = 300lm	<u>CCT</u> 27 = 2700K 30 = 3000K 35 = 3500K 40 = 4000K 57 = 5700K	<u>SEGMENTS</u> K = KIT

Example: TACC-EXT-FIT-300-35-K

3 TILE EXTERIOR STARTER CABLE

Purpose: Makes the electrical connection between the LED Driver and the TILE Exterior light emitting sheets to supply power to the system.

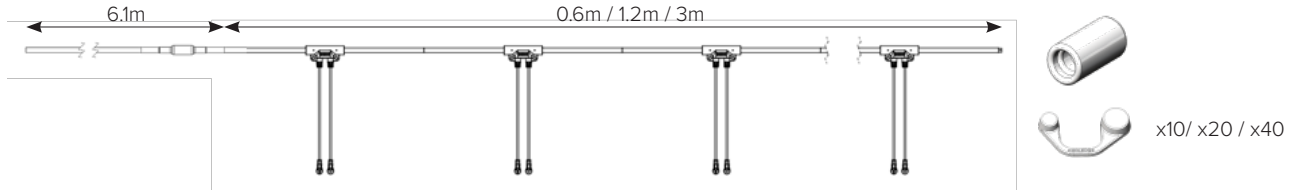

INCLUDED

- 1 6.1m section of 1.3 mm² wet location rated cable – no connectors (factory joined to variable length cable)
- 1 Section of 0.8 mm² wet location rated cable with over-molded “Y” connectors – choice of 0.6m or 1.2m (2ft or 4ft) length to power 1-4 runs, or 3m (10ft) length to power 5-10 runs
- 1 Termination Cap (tool-less) to cap cable end
- 10/20/40 Connector Caps (required) to cap unused connectors on TILE Exterior light emitting sheets

HOW TO ORDER

TCBL	-	EXT	-	STR	
<u>PRODUCT</u> TCBL = TILE Cable		<u>TYPE</u> EXT = Exterior		<u>FUNCTION</u> STR = Starter	<u>LENGTH</u> 22 = 2ft + 20ft (0.6m + 6.1m) 24 = 4ft + 20ft (1.2m + 6.1m) 30 = 10ft + 20ft (3m + 6.1m)

Example: TCBL-EXT-STR-30

ADDITIONAL WIRING ACCESSORIES

EXTENSION CABLES

Purpose: Supplies power to additional runs for layouts where more than 10 runs exist.

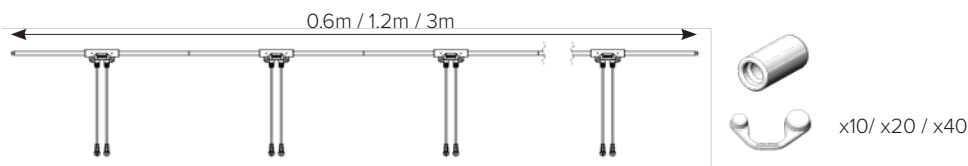

INCLUDED

- 1 section of 1.3 mm² wet location rated cable with over-molded “Y” connectors – choice of 0.6m-1.2m (2ft-4ft) length to power 1-4 runs or 3m (10ft) length to power 5-10 runs
- 1 Termination Cap (tool-less) to cap cable end
- 10/20/40 Connector Caps (required) to cap unused connectors on TILE Exterior light emitting sheets

HOW TO ORDER

TCBL	-	EXT	-	LNG	
<u>PRODUCT</u> TCBL = TILE Cable		<u>TYPE</u> EXT = Exterior		<u>FUNCTION</u> LNG = Length (Additional)	<u>LENGTH</u> 2 = 2ft (0.6m) 4 = 4ft (1.2m) 10 = 10ft (3m)

Example: TCBL-EXT-LNG-4

ADDITIONAL WIRING ACCESSORIES (cont.)

WATERPROOF CABLE SPLICE

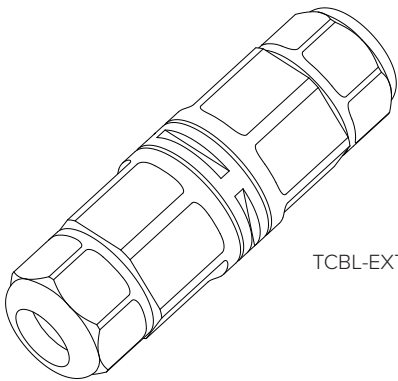

TCBL-EXT-SPL

Purpose: A waterproof connection for when two cables must be connected together.

Eg. to make a connection between a Starter Cable and an Extension Cable

Maximum outer cable jacket diameter 10mm

HOW TO ORDER

TCBL	-	EXT	-	SPL
<u>PRODUCT</u> TCBL = TILE Cable		<u>TYPE</u> EXT = Exterior		<u>FUNCTION</u> SPL = Splice

Example: TCBL-EXT-SPL

4 LED DRIVERS

Purpose: Convert AC mains (line) power to safe, low voltage DC power (required).

CE COMPLIANT DRIVERS - EXTERIOR

MODEL	TYPE	OUTPUT POWER (W)	INPUT VOLTAGE (VAC)	OUTPUT VOLTAGE (VDC)
PSS	Constant Voltage	90	NOM. 120-277	24

Detailed specifications including ordering codes for Coolege LED drivers are available in the following documents:

- Coolege CE Compliant LED Drivers - Specifications